

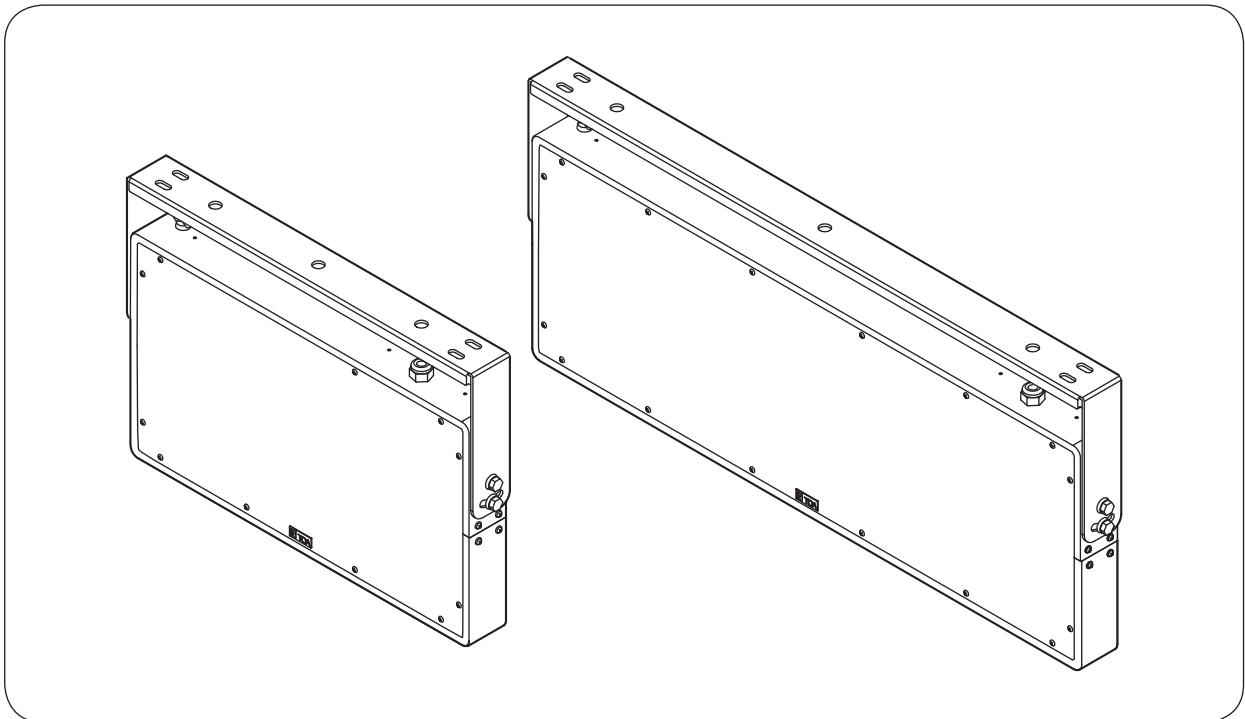

INSTRUCTION MANUAL

PLANE WAVE SPEAKERS PW-1230DB/1230DW
PW-1230SB/1230SW
PW-1430DB/1430DW
PW-1430SB/1430SW



Thank you for purchasing TOA's Plane Wave Speaker.
Please carefully follow the instructions in this manual to ensure long, trouble-free use of your equipment.

TOA Corporation

133-01-481-10

TABLE OF CONTENTS

1. SAFETY PRECAUTIONS	3
2. GENERAL DESCRIPTION	4
3. FEATURES	4
4. DIMENSIONAL DIAGRAM	5
4.1. PW-1230DB, PW-1230DW, PW-1230SB, and PW-1230SW	5
4.2. PW-1430DB, PW-1430DW, PW-1430SB, and PW-1430SW	5
5. SETTING	6
5.1. Impedance Setting	6
5.2. Beam Tilting and High Pass Filter Settings	6
6. INSTALLATION PRECAUTIONS	8
7. INSTALLATION	9
7.1. Speaker Installation	9
7.2. Installation of Double-Sided Type Speakers	10
7.3. Installing the Safety Wire	10
8. SPECIFICATIONS	11

1. SAFETY PRECAUTIONS

- Before installation or use, be sure to carefully read all the instructions in this section for correct and safe operation.
- Be sure to follow all the precautionary instructions in this section, which contain important warnings and/or cautions regarding safety.
- After reading, keep this manual handy for future reference.

Safety Symbol and Message Conventions

Safety symbols and messages described below are used in this manual to prevent bodily injury and property damage which could result from mishandling. Before operating your product, read this manual first and understand the safety symbols and messages so you are thoroughly aware of the potential safety hazards.



WARNING

Indicates a potentially hazardous situation which, if mishandled, could result in death or serious personal injury.



CAUTION

Indicates a potentially hazardous situation which, if mishandled, could result in moderate or minor personal injury, and/or property damage.



WARNING

When Installing the Unit

- Refer all installation work to the dealer from whom the speaker was purchased. Installation requires extensive technical knowledge and experience. The speaker may fall off if incorrectly installed, resulting in possible personal injury.
- Install the unit only in a location that can structurally support the weight of the unit and the mounting bracket. Doing otherwise may result in the unit falling down and causing personal injury and/or property damage.
- When installing the unit in the snowy area, take appropriate measures to prevent snow from lying on the unit. If the snow lies on the unit, the unit may fall, causing personal injuries.
- Owing to the unit's size and weight, be sure that at least two persons are available to install the unit. Failure to do so could result in personal injury.
- Do not use other methods than specified to mount the bracket. Extreme force is applied to the unit and the unit could fall off, possibly resulting in personal injuries.
- Fit the unit with a safety wire to prevent it from falling. If not fitted, the unit could fall off, resulting in personal injury.
- Use nuts and bolts that are appropriate for the ceiling's or wall's structure and composition. Failure to do so may cause the speaker to fall, resulting in material damage and possible personal injury.

- Tighten each nut and bolt securely. Ensure that the bracket has no loose joints after installation to prevent accidents that could result in personal injury.

- Be sure to use the supplied mounting bracket in combination. Doing otherwise may cause the speaker to fall, resulting in personal injury.

- Do not mount the unit in locations exposed to constant vibration. The mounting bracket can be damaged by excessive vibration, potentially causing the unit to fall, which could result in personal injury

- Avoid installing the speaker in locations close to the seashore or in indoor swimming facilities that are not well ventilated. In such locations, the bracket may be vulnerable to corrosion, eventually allowing the speaker to fall resulting in personal injury.



CAUTION

When Installing the Unit

- Avoid touching the unit's sharp metal edge to prevent injury.

When the Unit is in Use

- Do not operate the unit for an extended period of time with the sound distorting. Doing so may cause the unit to heat, resulting in a fire.

- Do not stand or sit on, nor hang down from the unit as this may cause it to fall down or drop, resulting in personal injury and/or property damage.

- Have the unit checked periodically by the shop from where it was purchased. Failure to do so may result

in corrosion or damage to the unit or its mounting bracket that could cause the unit to fall, possibly causing personal injury.

· Never connect a 170 Ω speaker lead to high impedance 100 V line, as this will damage the speaker and amplifier.

2. GENERAL DESCRIPTION

The Plane Wave Speaker features a flat speaker system equipped with plane wave units, realizing a narrow directivity pattern by radiating plane wave sound.

Since the Plane Wave Speaker can deliver sound output toward a limited target area, it is suited for use in locations such as station platforms and escalator areas that require information announcements to be broadcast, and in such spaces as museums and art galleries where the reverberation time is long.

The Plane Wave Speaker lineup includes the following 8 models.

- PW-1230DB and PW-1230DW (compact double-sided radiation type)
- PW-1230SB and PW-1230SW (compact single-sided radiation type)
- PW-1430DB and PW-1430DW (large double-sided radiation type)
- PW-1430SB and PW-1430SW (large single-sided radiation type)

Note: The rightmost letter of each model number indicates color: “B” for black and “W” for light ivory.

A double-sided radiation type radiates sound both backward and forward, while a single-sided radiation type radiates sound forward only.

The most appropriate model can be selected depending on the condition of installation location and application.

3. FEATURES

- Two types of Plane Wave Speakers available: A compact type (PW-1230 series) consisting of 2 plane wave units and a large type (PW-1430 series) consisting of 4 plane wave units.
- Sound dispersion range is narrow in both horizontal and vertical directions, enabling sound output to be delivered toward a limited target area. Less susceptible to the influence of sound reflections from the ceiling and floor, allowing clear sound to be delivered even in spaces with poor acoustic conditions such as long reverberation time.
- A built-in beam tilting function for tilting sound radiation direction about 5° downward from the horizontal
- A built-in high pass filter for cutting low frequencies
- Compliant to IPX4 (IEC60529)* water protection rating
- Stainless steel-made metal parts of the plane wave unit and the speaker enclosure

* The performance of the unit is not harmfully affected even if water is splashed upon the unit from every direction.

4. DIMENSIONAL DIAGRAM

4.1. PW-1230DB, PW-1230DW, PW-1230SB, and PW-1230SW

[Top]

Unit: mm (in)

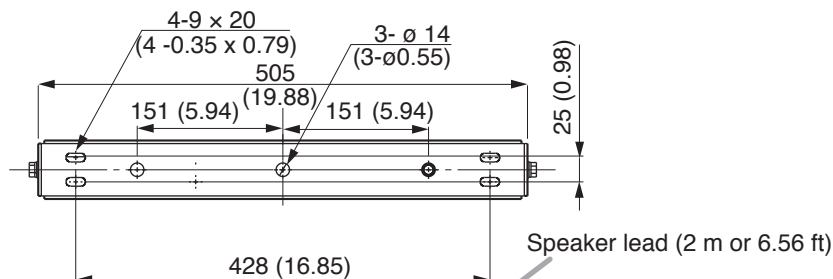

[Front]

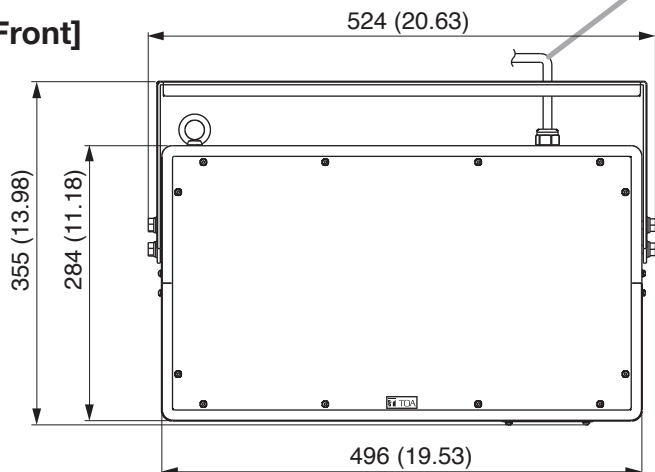

[Side]

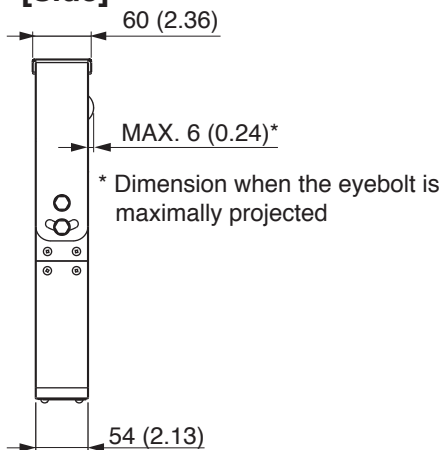

[Bottom]

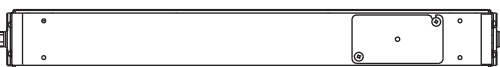

4.2. PW-1430DB, PW-1430DW, PW-1430SB, and PW-1430SW

[Top]

Unit: mm (in)

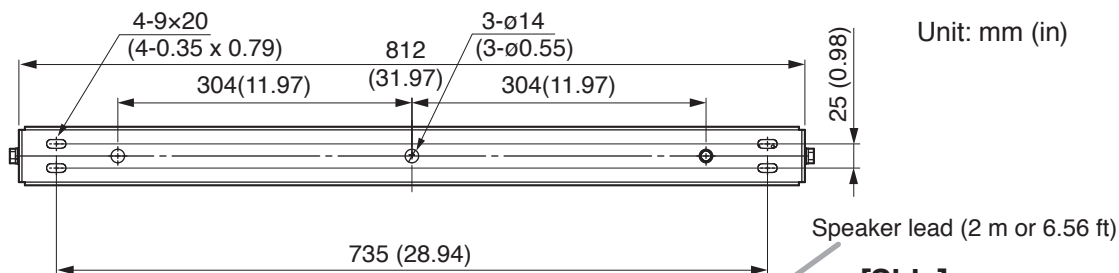

[Front]

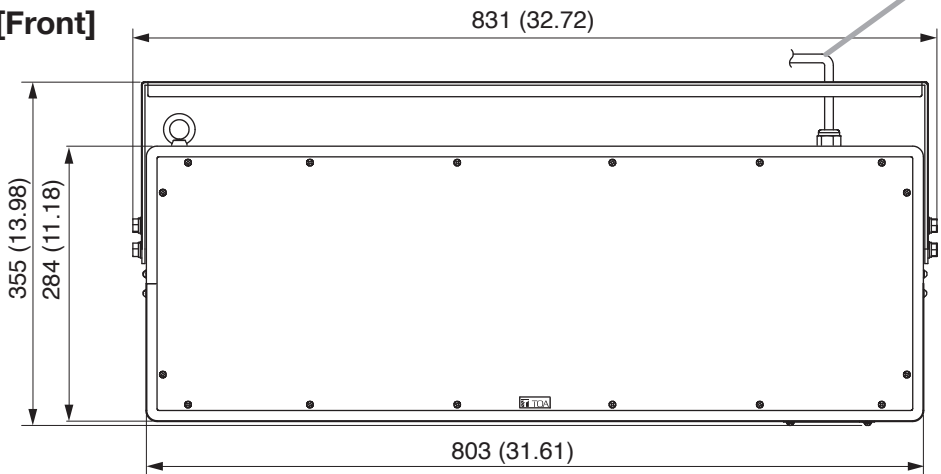

[Side]

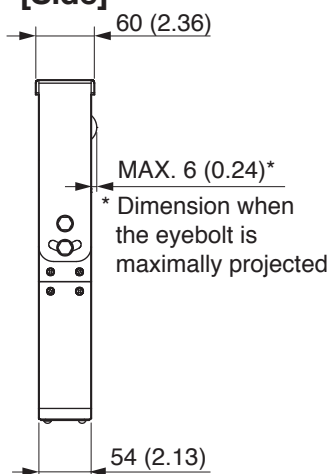

[Bottom]



5. SETTING

5.1. Impedance Setting

Referring to the table below, use the speaker leads corresponding to your desired impedance (rated input) for connection to the amplifier.

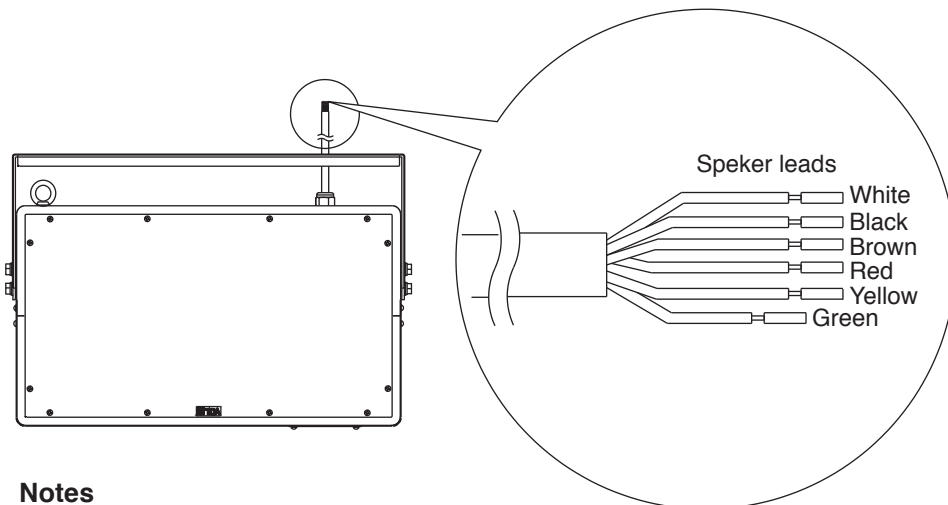

Notes

- Be sure to insulate unused leads so as not to short-circuit.
- Waterproof the cable joint by wrapping insulating tape around it when the joint may be exposed to rain or water.

Input	High impedance 100 V line	—	30 W	15 W	10 W	5 W
	High impedance 70 V line	30 W	15 W	7.5 W	5 W	2.5 W
Impedance		170 Ω	330 Ω	670 Ω	1 kΩ	2 kΩ
Speaker leads	HOT	Green	Black	Brown	Red	Yellow
	COM	White	White	White	White	White



CAUTION

The green lead is for high impedance 70 V line use only. Never use it on high impedance 100 V line since the amplifier or speaker itself may be damaged.

5.2. Beam Tilting and High Pass Filter Settings

To change the setting, loosen 2 screws on the bottom surface of the speaker, open the switch cover, then change the setting using the toggle switch.

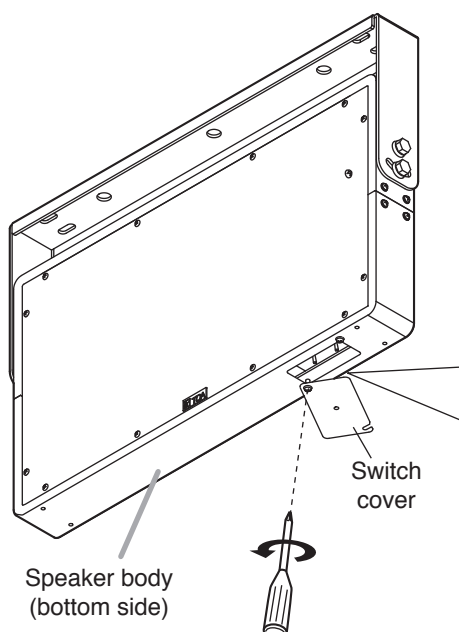

These switches are factory-preset as follows.

Switch name	Setting
BEAM TILTING	FLAT
HIGH PASS FILTER	OFF

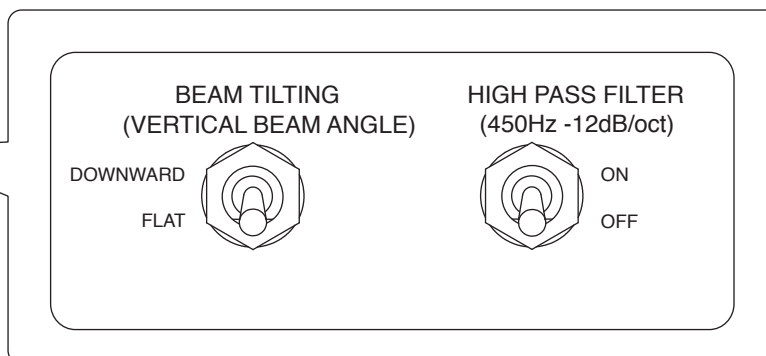

5.2.1. Beam tilting function

Shifting the beam tilting switch to “DOWNWARD” causes the sound radiation to be directed about 5° downward from the horizontal.

Switch setting	Radiation direction
FLAT	0°
DOWNWARD	5° Downward

[When shifted to “FLAT”]

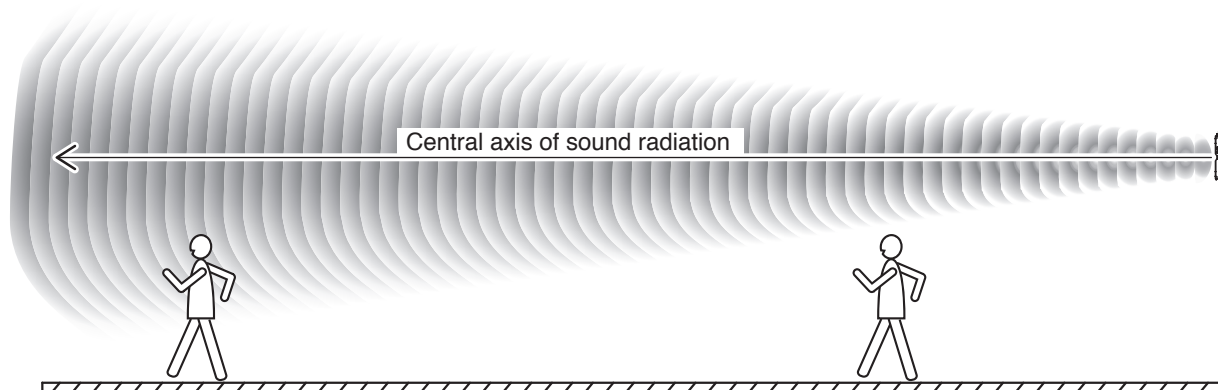

[When shifted to “DOWNWARD”]

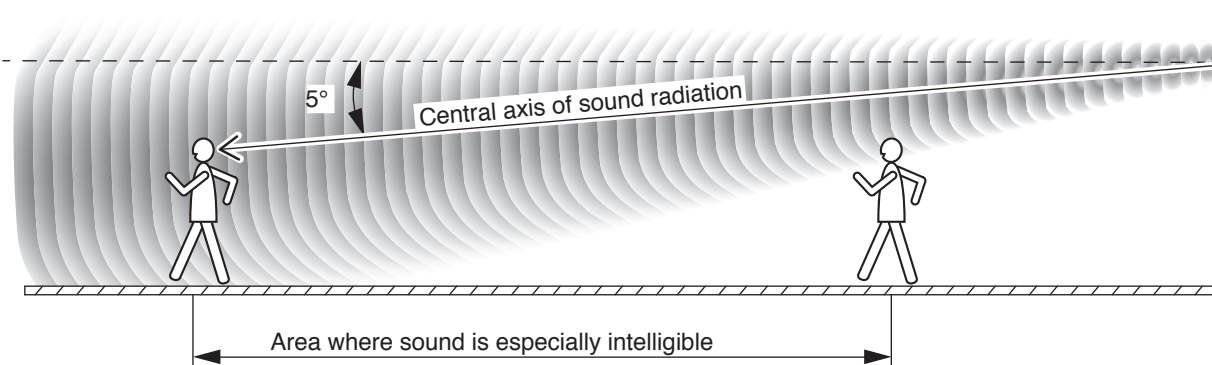

5.2.2. High pass filter function

Both types of speakers provide dispersion characteristics shown as radiation patterns at right.

To cut unwanted low-frequency sounds radiated outside from the coverage area, shift the high pass filter switch to the “ON” position. Frequencies below 450 Hz are cut at -12 dB/oct. In this case, low-frequency sounds in the coverage area are cut as well, however, this will have little influence on sound intelligibility.

[Radiation patterns]

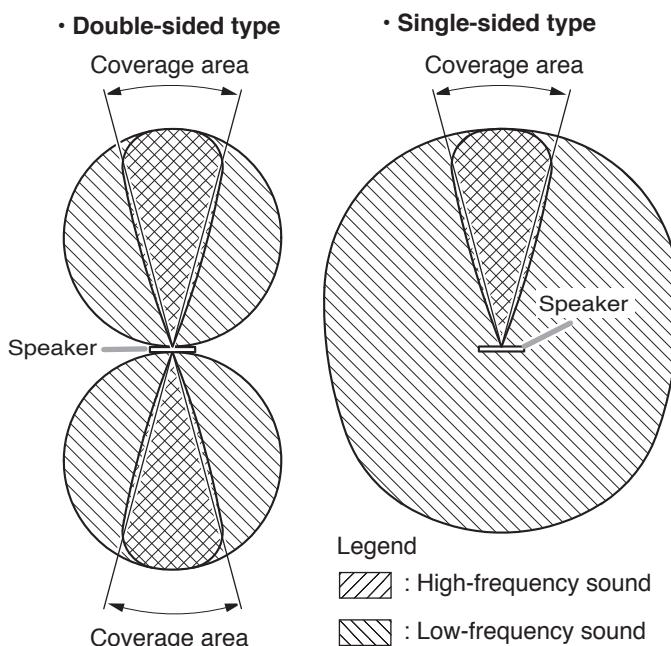

These radiation patterns are viewed from above the speakers.

6. INSTALLATION PRECAUTIONS

The Plane Wave Speaker features splash-proof construction (IPX4 water protection) and can be installed under eaves not directly exposed to rain or snow. But the speaker installation orientation is limited as follows. Be sure to follow the instructions below. Failure to do so may cause damage to the speaker.

- Install the speaker so that its bottom surface is positioned downward. Five air vents are provided in the bottom surface. Never block these air vents.

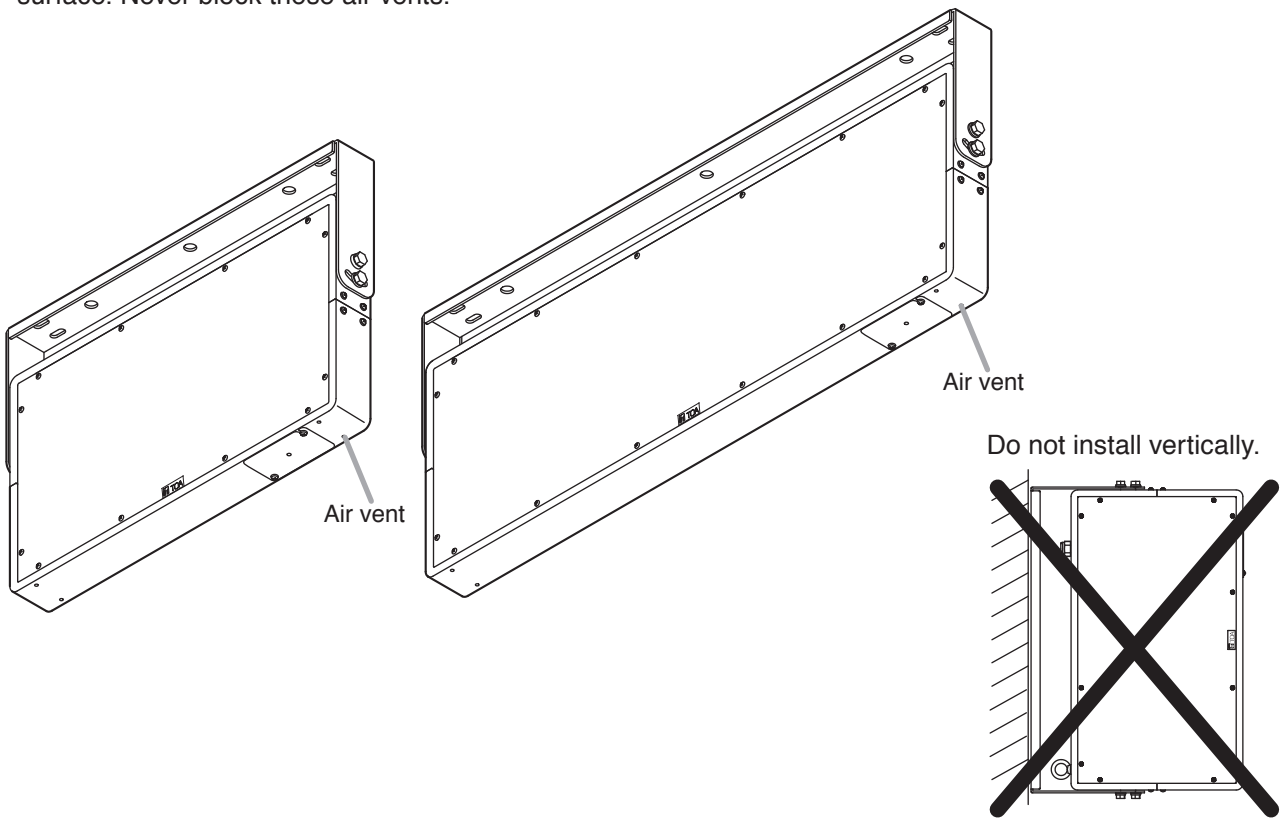

- PW-1230SB/1230SW/1430SB/1430SW (single-sided radiation type)

Install the speaker within a downward tilt angle of up to 30°.

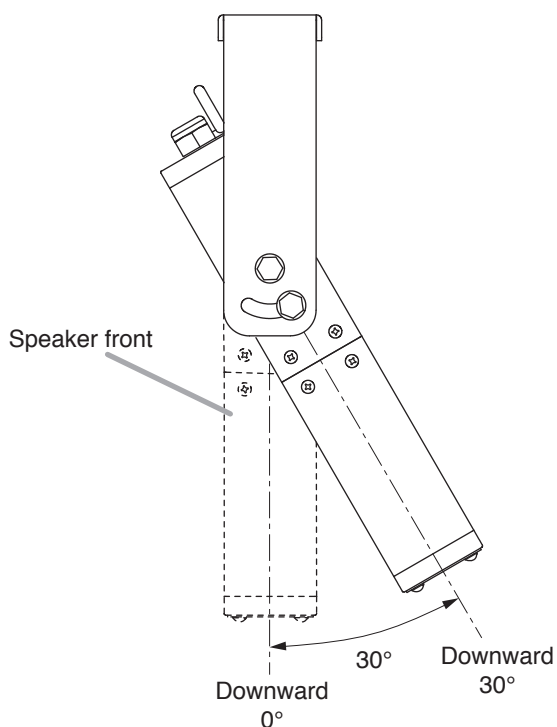

- PW-1230DB/1230DW/1430DB/1430DW (double-sided radiation type)

Install the speaker within a downward tilt angle of only 0°.

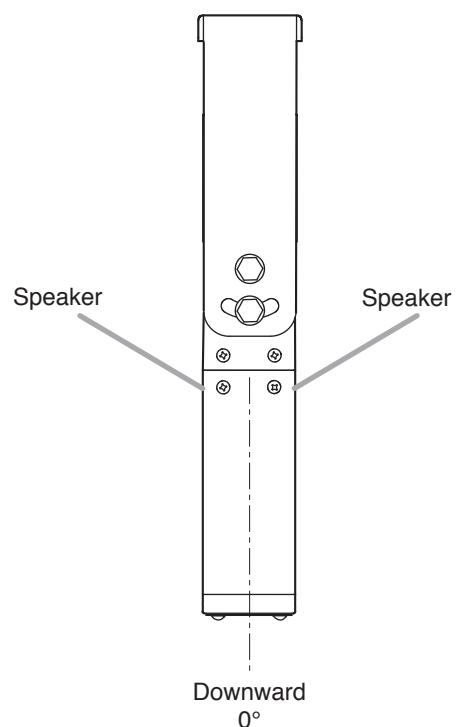

7. INSTALLATION

WARNING

Be sure to observe the following instructions. Failure to do so may cause the unit to fall, possibly resulting in personal injury.

- Use bolts and nuts that are appropriate for the material and structure at the installation location.
- Securely tighten all bolts.
- Be sure to use at least 4 bolts to secure the mounting bracket to the installation location.

7.1. Speaker Installation

Step 1. Remove the mounting bracket from the unit.
Remove the bolts on the unit's both sides to detach the bracket.

After removing the bolts, detach the protection sheet inserted between the mounting bracket and the bolts on each side of the unit. The removed protection sheets are no more used at speaker installation.

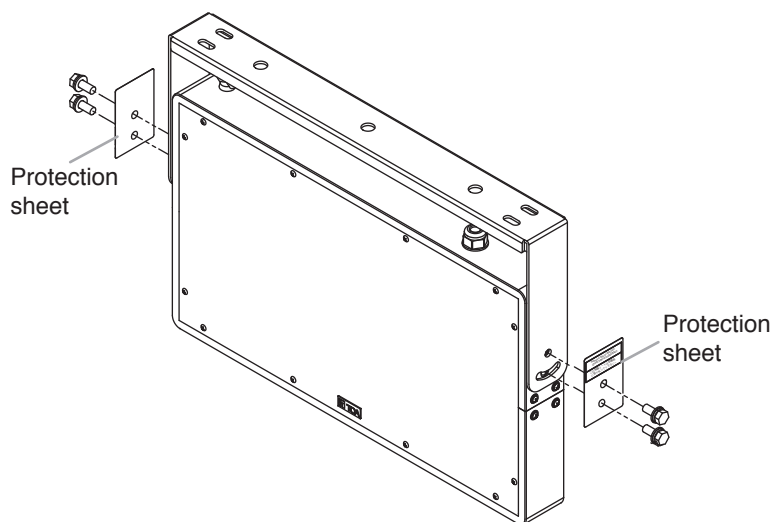

Step 2. Secure the mounting bracket to the installation location.

Note
Bolts and nuts for fixing the mounting bracket to the installation location are not included. Separately prepare them.

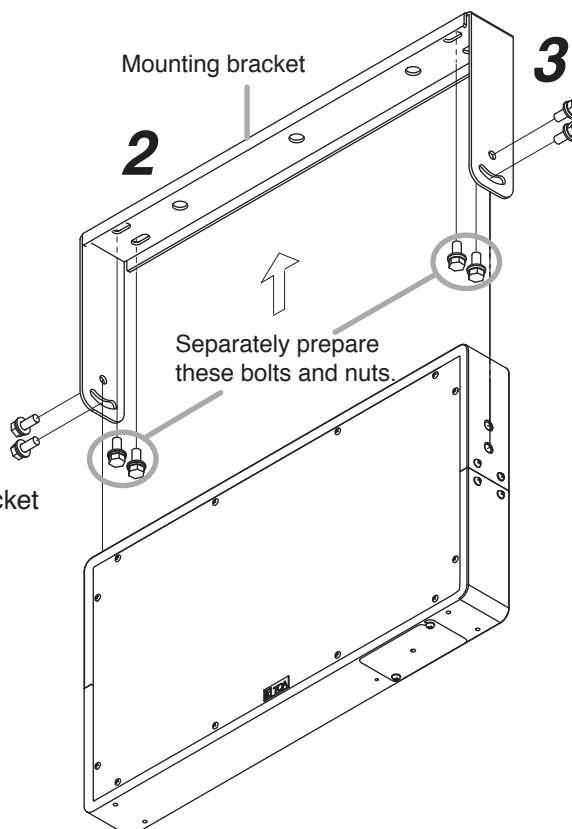

Step 3. Secure the speaker to the mounting bracket
Use the bolts removed in step 1 above.

7.2. Installation of Double-Sided Type Speakers

The double-sided type speakers (PW-1230DB/1230DW/1430DB/1430DW) emit positive pressure wave from their front (the side with TOA logo affixed) and negative pressure wave from their rear. It is recommended to orient these speakers as shown below when installing them in platforms or long narrow passages.

[Installation example]

Positive pressure wave : "Positive"

Negative pressure wave : "Negative"

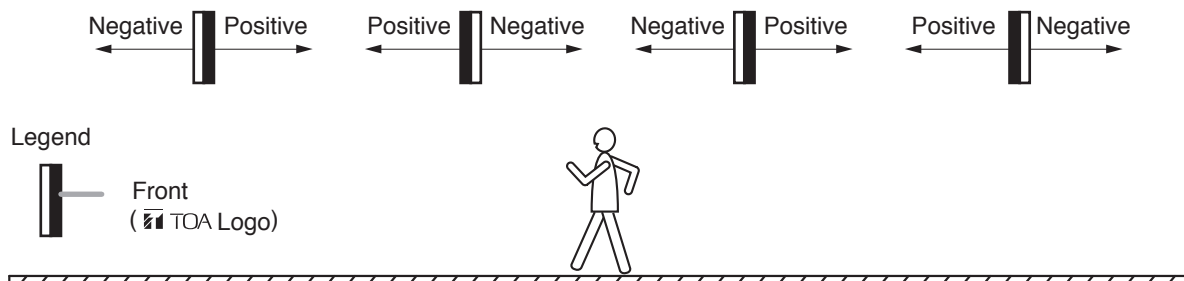

7.3. Installing the Safety Wire



WARNING

Connect a safety wire to the unit to prevent it from falling. If not connected, the unit could fall, resulting in personal injury.

Secure to rigid structure such as iron frame or steel beam.

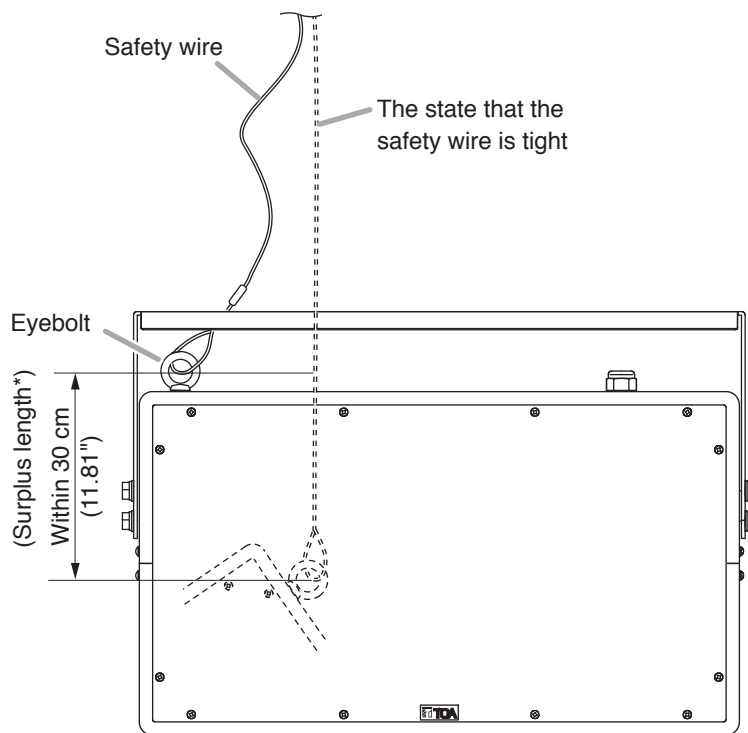

* The surplus length refers to the length with enough slack.

Notes

- No safety wire is supplied with the speaker. Separately prepare a safety wire that meets the following requirements.
 - The diameter of the safety wire must be 2 mm (0.08") or more.
 - The surplus length* of the safety wire must be within 30 cm (11.81") from the state that the safety wire is tight.
- Never loosen the eyebolt.
 - If loosened, rain or water gets into the speaker, resulting in speaker failure.

8. SPECIFICATIONS

Model No.	PW-1230DB , PW-1230DW	PW-1230SB , PW-1230SW
Type of Radiation	Double-sided radiation	Single-sided radiation
Rated Input	30 W	
Rated Impedance	High impedance 100 V line 330 Ω (30 W), 670 Ω (15 W) , 1 kΩ (10 W) , 2 kΩ (5 W) High impedance 70 V line 170 Ω (30 W), 330 Ω (15 W), 670 Ω (7.5 W) , 1 kΩ (5 W), 2 kΩ (2.5 W)	
Sensitivity	86 dB (1 W, 1 m equivalent measured at 4 m, 1 k – 10 kHz) 86 dB (1 W measured at 1 m, 1 k – 10 kHz) (Beam tilting: FLAT, High pass filter: OFF)	87 dB (1 W, 1 m equivalent measured at 4 m, 1 k – 10 kHz) 87 dB (1 W measured at 1 m, 1 k – 10 kHz) (Beam tilting: FLAT, High pass filter: OFF)
Frequency Response	300 Hz – 17.5 kHz (Beam tilting: FLAT, High pass filter: OFF)	450 Hz – 17.5 kHz (Beam tilting: FLAT, High pass filter: OFF)
Directivity Angle	Horizontal: 38° (2 kHz, 1/3 octave band), Vertical: 75° (2 kHz, 1/3 octave band)	
Speaker Unit	Plane wave unit (152 x 214 mm or 5.98" x 8.43") x 2 pcs.	
Setting Switch	Beam tilting (tilts radiation axis 5° downward) : FLAT/DOWNWARD High pass filter (450 Hz, –12 dB/oct) : OFF/ON	
Speaker Cord	Φ 9 mm (0.35"), 6-core cabtyre cable, 2 m (6.56 ft)	
Water Protection	IPX4	
Operating Temperature	–10 to +50 °C (14 to 122 °F)	
Finish	Enclosure, Punched net, and Mounting bracket: Stainless, semi-gloss, paint	
Color	PW-1230DB : Black PW-1230DW : Light ivory	PW-1230SB : Black PW-1230SW : Light ivory
Dimensions	524 (w) x 355 (h) x 60 (d) mm (20.63" x 13.98" x 2.36") (including mounting bracket)	
Weight	7.3 kg (16.09 lb) (including mounting bracket)	7.8 kg (17.2 lb) (including mounting bracket)

Note: The design and specifications are subject to change without notice for improvement.

Model No.	PW-1430DB , PW-1430DW	PW-1430SB , PW-1430SW
Type of Radiation	Double-sided radiation	Single-sided radiation
Rated Input	30 W	
Rated Impedance	High impedance 100 V line 330 Ω (30 W), 670 Ω (15 W) , 1 kΩ (10 W) , 2 kΩ (5 W) High impedance 70 V line 170 Ω (30 W), 330 Ω (15 W), 670 Ω (7.5 W) , 1 kΩ (5 W), 2 kΩ (2.5 W)	
Sensitivity	88 dB (1 W, 1 m equivalent measured at 4 m, 1 k – 10 kHz) 85 dB (1 W measured at 1 m, 1 k – 10 kHz) (Beam tilting: FLAT, High pass filter: OFF)	90 dB (1 W, 1 m equivalent measured at 4 m, 1 k – 10 kHz) 87 dB (1 W measured at 1 m, 1 k – 10 kHz) (Beam tilting: FLAT, High pass filter: OFF)
Frequency Response	250 Hz – 17.5 kHz (Beam tilting: FLAT, High pass filter: OFF)	400 Hz – 17.5 kHz (Beam tilting: FLAT, High pass filter: OFF)
Directivity Angle	Horizontal: 19° (2 kHz, 1/3 octave band), Vertical: 78° (2 kHz, 1/3 octave band)	
Speaker Unit	Plane wave unit (152 x 214 mm or 5.98" x 8.43") x 4 pcs.	
Setting Switch	Beam tilting (tilts radiation axis 5° downward) : FLAT/DOWNWARD High pass filter (450 Hz, -12 dB/oct) : OFF/ON	
Speaker Cord	Φ 9 mm (0.35"), 6-core cabtyre cable, 2 m (6.56 ft)	
Water Protection	IPX4	
Operating Temperature	-10 to +50°C (14 to 122°F)	
Finish	Enclosure, Punched net, and Mounting bracket: Stainless, semi-gloss, paint	
Color	PW-1430DB : Black PW-1430DW : Light ivory	PW-1430SB : Black PW-1430SW : Light ivory
Dimensions	831 (w) x 355 (h) x 60 (d) mm (32.72" x 13.98" x 2.36") (including mounting bracket)	
Weight	11.4 kg (25.13 lb) (including mounting bracket)	11.9 kg (26.23 lb) (including mounting bracket)

Note: The design and specifications are subject to change without notice for improvement.

Traceability Information for Europe

Manufacturer:
TOA Corporation
7-2-1, Minatojima-Nakamachi, Chuo-ku, Kobe, Hyogo,
Japan

Authorized representative:
TOA Electronics Europe GmbH
Suederstrasse 282, 20537 Hamburg,
Germany